

# Bendi®



## **MODEL B40AC**

### **4-WHEEL BENDI**

### **ELECTRIC MULTI-PURPOSE NARROW AISLE ARTICULATED FORKLIFT TRUCK**

The Landoll Bendi B40AC is a 4-wheel articulating forklift that maximizes cube utilization while providing front loader versatility. Increased productivity, operator comfort and safety are the primary benefits.

#### **FEATURES**

- 4,000lb/1,818kg Capacity
- Lift Heights to 360"/9.14M
- 78"/1.98M Stacking Aisle
- 11.2"(285mm) Sideshifter and 36"(914mm) High Load Backrest Standard
- Dual Inside/Outside Capability
- AC Powered Drive Motors
- Cold Storage Conditioned to -22°F (-29°C)

#### **DRIVE TRAIN**

- Large Diameter Smooth Rubber Drive Tires
- Polyurethane Load Tires
- 180° Front-End Articulation/Steering
- Heavy Duty Dual Rear Wheel Planetary Drives
- Powerful Drive and Hydraulic Motors

#### **ENGINEERING**

- Forward and Rearward Mast Tilt
- Heavy Duty Chassis Design
- Rotation via Dual Taper Roller Bearings, with 3-Year Warranty on Articulation
- Accepts Class II Attachments
- Easily Accessible Components for Low Cost Maintenance

#### **ERGONOMICS & SAFETY**

- Hydraulic Power Steering
- Comfortable Seated Operation with all Truck Controls within Easy Reach
- 4-Post Heavy-Duty Overhead Guard
- Safety Dead Man Seat Switch
- Clearview 3-Stage or 4-Stage Mast
- Key Switch, Horn, Hourmeter, Adjustable Suspension Seat and Steering Column, Seatbelt and Arm Rest are Standard

#### **ELECTRICAL**

- AC Powered Dual Traction Motor Controller
- AC Powered Hydraulic Pump Motor Controller
- Battery Discharge Indicator with Lift Interrupt
- Lighting and Alarm Accessories Available
- Provisions for RF Terminals Provided



## **LANDOLL CORPORATION**

MATERIAL HANDLING PRODUCT DIVISION

[WWW.LANDOLL.COM/MHP](http://WWW.LANDOLL.COM/MHP)

# Bendi B40AC - 4,000 lbs (1,818kg)

Electric Multi-Purpose

Articulated Forklift Truck

## TECHNICAL & DIMENSION DATA



### TECHNICAL DATA

MODEL			B40AC
Capacity		lbs/kg	4,000 / 1,818
Load Center		in/mm	24 / 600
Power Source			Battery, electric
Weight with Battery		lbs/kg	13,770 / 6,259
Travel Speed	Loaded	mph/kph	6.5 / 10.5
	Unloaded	mph/kph	7 / 11.3
Lift Speed	Loaded	fpm/mpm	90 / 27.4
	Unloaded	fpm/mpm	110 / 33.5
Lowering Speed	Loaded	fpm/mpm	100 / 30.5
	Unloaded	fpm/mpm	90 / 27.4
Mast Tilt*	FWD/RWD	Deg./in/M	3/3 under 276/7.01
	FWD/RWD	Deg./in/M	1/3 over 276/7.01
Lost Load Center	a	in/mm	12 / 310
Wheelbase	b	in/mm	63 / 1,600
Overall Length to Face of Forks	c	in/mm	103 / 2,620
Underclearance	d	in/mm	3 / 76
Cab Floor Height	e	in/mm	31 / 787
Seat Height	f	in/mm	51 / 1,295
Overhead Guard Height	g	in/mm	87 / 2,209
Chassis Width	h	in/mm	48 / 1,219
Gradeability	Unloaded	%	15
	Loaded	%	15
Hydraulic Motor Rating (AC)		kW	12
Drive Motor Rating (AC)	Dual Rear	kW	5.6 ea - 11.2 total
Wheel Sizes	Front (2 each)	in/mm	14x5 / 355x127
	Rear (2 each)	in/mm	18x7 / 457x178
Traction Control Type			AC
Front Articulation	m	Deg.	180

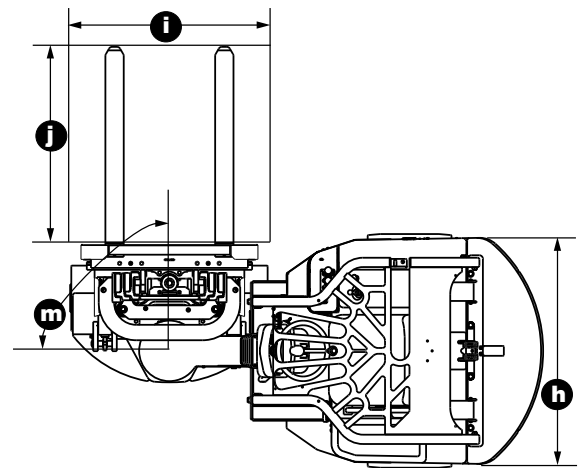
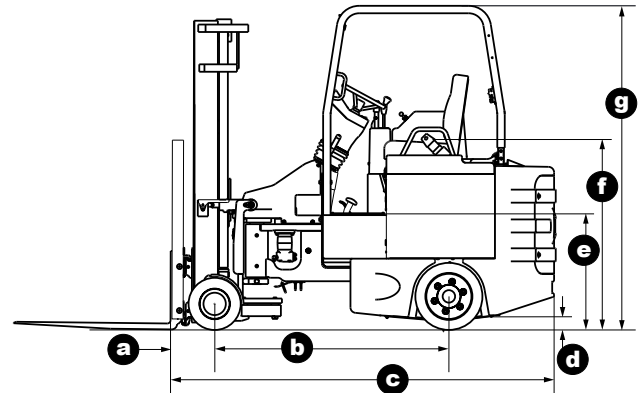

### AISLE DIMENSIONS

LOAD DEPTH X WIDTH (j x i)	MINIMUM CLEAR AISLE
40" x 48" (1,000 x 1,200 mm)	70" (1,778 mm)
48" x 40" (1,200 x 1,000 mm)	78" (1,981 mm)
MIN. CLEAR TRANSFER AISLE	108" (2,743 mm)

### MAST DIMENSIONS

MAST DIMENSIONS 3 STAGE FULL FREE LIFT					
Lift Height		Lowered Height		Free Lift	
Inches	Meters	Inches	Meters	Inches	Meters
188	4.78	83	2.11	61	1.55
198	5.03	87	2.21	65	1.65
216	5.49	95	2.41	73	1.85
224	5.69	98	2.49	74	1.88
240	6.10	106	2.69	82	2.08
258	6.55	115	2.92	91	2.31
276	7.01	122	3.10	98	2.49
294	7.47	128	3.25	104	2.64
312	7.92	132	3.35	108	2.74
322	8.18	137	3.48	113	2.87
360	9.14	156	3.96	132	3.35
MAST DIMENSIONS 4 STAGE FULL FREE LIFT					
250	6.35	87	2.21	62	1.57
276	7.01	95	2.41	70	1.78
294*	7.47	101	2.57	76	1.93
312*	7.92	107	2.72	82	2.08

\*Tilt restricted to 1 degree fwd, 2 degree back.

The specifications contained in this spec sheet are subject to change at any time without notice. Actual dimensions and performance data given herein may vary due to manufacturing tolerances.



### RECOMMENDED BATTERIES

<b>BATTERY DESIGNATION: 24-85-19, 48 VOLT, 765 AHC (6 HOUR RATE)</b>
Nominal size 25 15/16" X 44 9/16" X 22 5/8" (66 x 113 x 58 cm)
Truck compartment size: 26" x 44 3/4" x 23" (66x 114 x 58 cm)
Battery weight min, 2,600 lbs (1181 kg) - max 3,100 lbs. (1409 kg)
Leads are at position A, 12" long, with SB 350 amp blue connector

1900 NORTH STREET • MARYSVILLE, KS 66508 • (800).428.5655 • www.landoll.com/mhp

