

WPB/RPB Series

Walkie and Walkie/Rider Models

6,000 & 8,000 lb.
Capacity

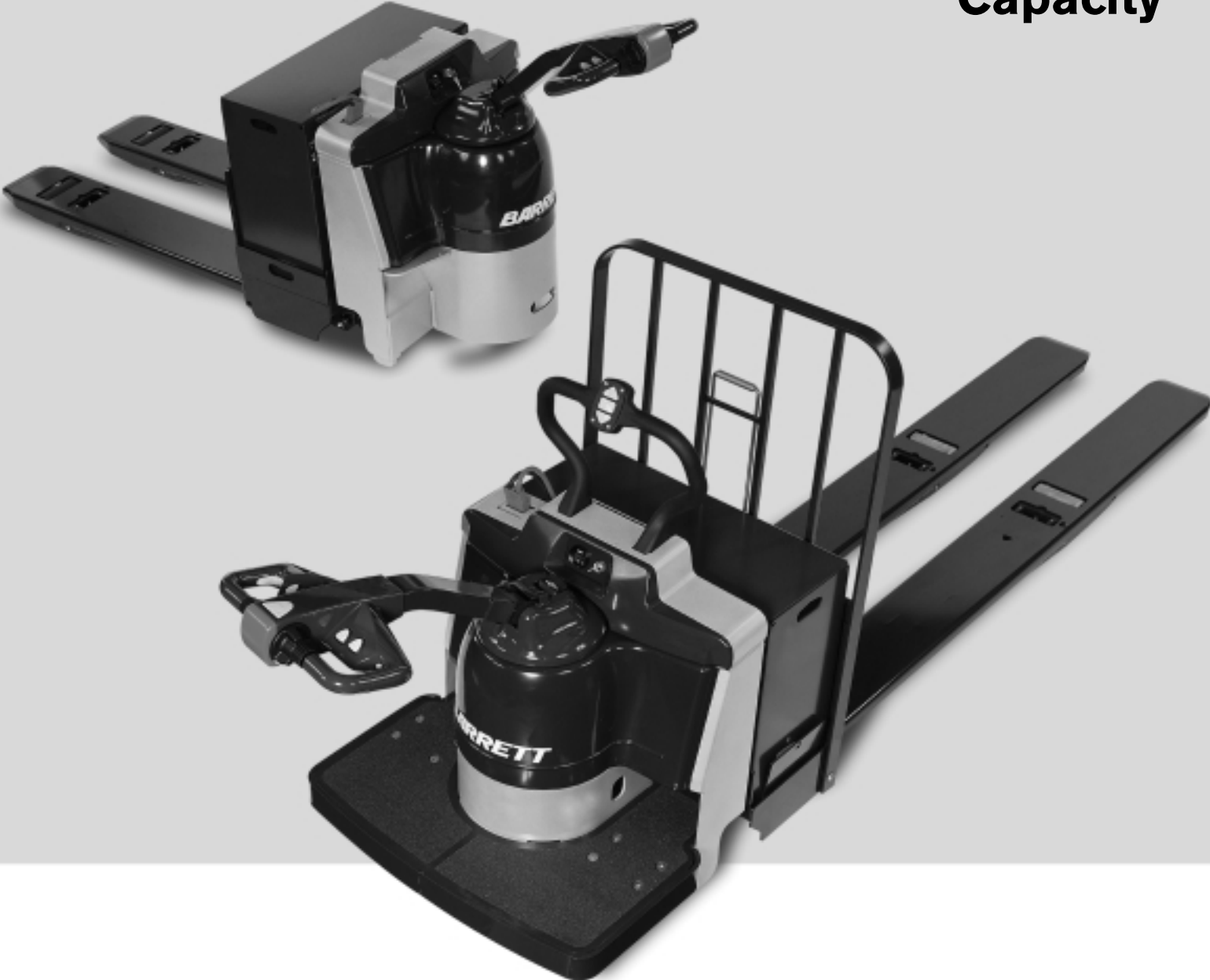

Dimensions

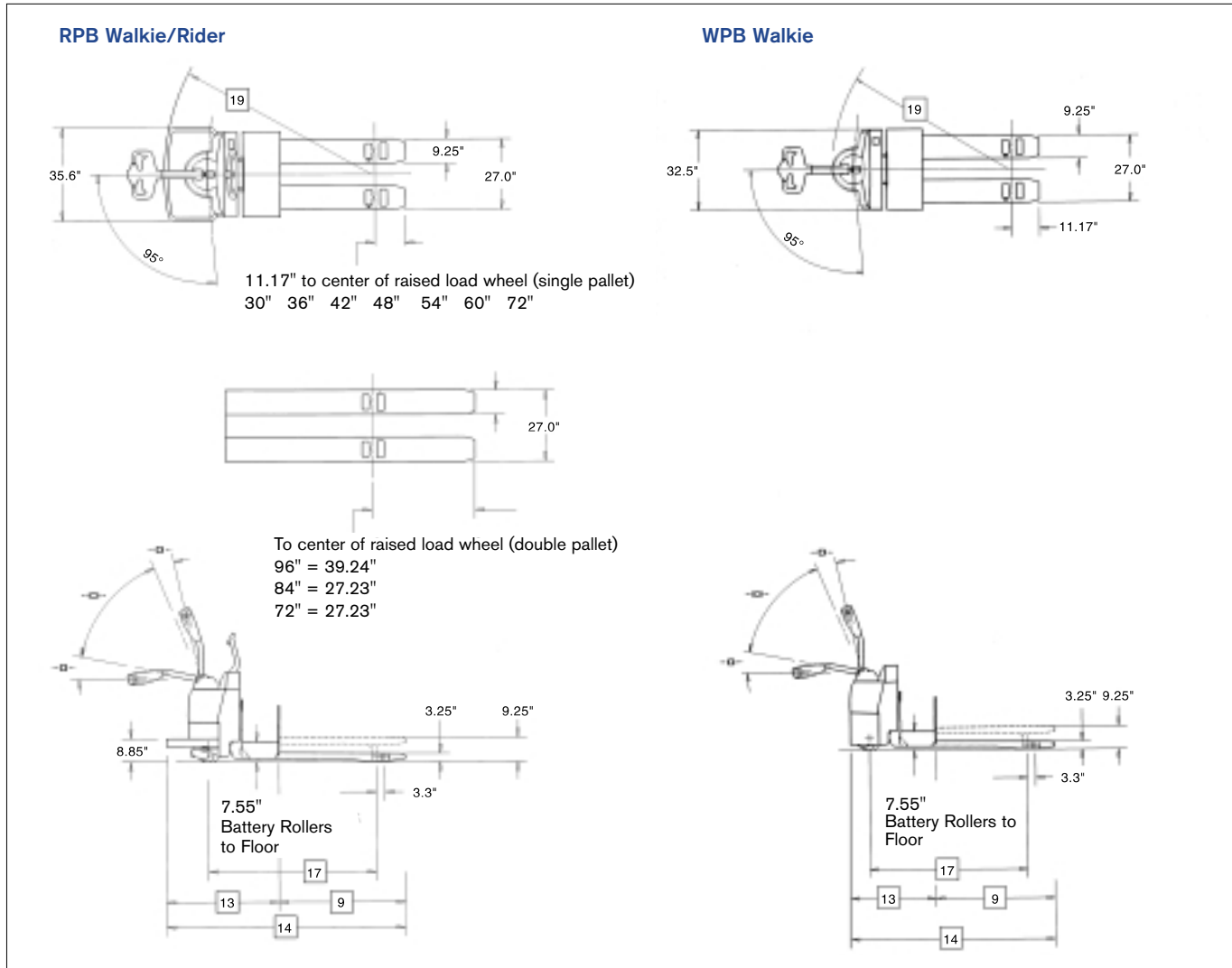

Specifications

| WPB Walkie | | Single Pallet | | | Double Pallet | | | | |
|----------------|--|-------------------------------------|-------------|-------------|---------------|-------------|-------------|------------|--|
| | | 36 | 42 | 48 | 84 | 96 | 9 | | |
| SPECIFICATIONS | 9 Nominal Fork Length | in | 36 | 42 | 48 | 84 | 96 | 9 | |
| | | in (mm) | 35.7 (907) | 41.7 (1059) | 47.7 (1212) | 83.7 (2126) | 95.7 (2431) | | |
| | 17 Wheelbase (Forks Raised) | in (mm) | 51.6 (1311) | 57.6 (1463) | 63.6 (1615) | 83.5 (2121) | 83.5 (2121) | 17 | |
| | 18 Grade Clearance | % | 36.4 | 32.5 | 29.4 | 22.4 | 22.4 | 18 | |
| | 19 Turning Radius | in (mm) | 59.6 (1513) | 65.5 (1665) | 71.5 (1817) | 91.4 (2323) | 91.4 (2323) | 19 | |
| | 20 Right Angle Stacking Aisle ^{1,2} | | | | | | | 20 | |
| | | 40" Load width | in (mm) | 69 (1753) | 75 (1905) | 81 (2057) | 118 (2997) | 130 (3302) | |
| | | 42" Load width | in (mm) | 69 (1753) | 75 (1905) | 81 (2057) | 118 (2997) | 130 (3302) | |
| | | 48" Load width | in (mm) | 68 (1727) | 74 (1880) | 80 (2032) | 118 (2997) | 130 (3302) | |
| | | 90° Intersecting Aisle ¹ | | | | | | | |
| | | 40" Load width | in (mm) | 56 (1422) | 59 (1499) | 62 (1524) | 74 (1880) | 77 (1956) | |
| | | 42" Load width | in (mm) | 57 (1448) | 61 (1549) | 64 (1626) | 75 (1905) | 80 (2032) | |
| | | 48" Load width | in (mm) | 61 (1549) | 64 (1626) | 67 (1702) | 78 (1981) | 87 (2210) | |
| | 21 Truck weight | lb (kg) | 985 (447) | 1012 (495) | 1040 (472) | 1179 (535) | 1215 (551) | 21 | |

¹ Add 6-8" for ease of operation

² Includes 1" clearance on each side of load

6,000 & 8,000 lb. capacity

Main Truck Specifications

| CHARACTERISTICS | | | | BARRETT | BARRETT | BARRETT | BARRETT | |
|-----------------|-----------------------------------|---------------------------|------------|---------------------------------------|---------------------------|---------------------------------------|---------------------------|----|
| 1 | Manufacturer | | | BARRETT | BARRETT | BARRETT | BARRETT | 1 |
| 2 | Model | Model Designation | | WPB-60 | WPB-80 | RPB-60 | RPB-80 | 2 |
| | | Long Model Code | | WPTT1W1G60 V | WPTT1W1G80 V | RPTT1W2G60 V | RPTT1W2G80 V | |
| 3 | Load Capacity | | lb (kg) | 6000 (2700) | 8000 (3600) | 6000 (2700) | 8000 (3600) | 3 |
| 4 | Power Type | Electric | | 24 Volt | | 24 Volt | | 4 |
| 5 | Operator Type | | | Walkie | | Walkie/Rider | | 5 |
| 6 | Tire Type | | | Solid Rubber | | Solid Rubber | | 6 |
| 7 | Wheels | Number - front/rear | | 1 / 2 | | 1 / 2 | | 7 |
| 8 | Size | Outside Spread | in (mm) | 27 (686) | | 27 (686) | 27 (686) | 8 |
| | | Nominal Length | in (mm) | 48 (1219) | | 48 (1219) | 96 (2438) | 9 |
| | Height | Raised Position | in (mm) | 9.25 (234) | | 9.25 (234) | | 10 |
| | | Lowered Position | in (mm) | 3.25 (82.6) | | 3.25 (82.6) | | 11 |
| 12 | Individual Fork Width | | in (mm) | 9.25 (234) | | 9.25 (234) | | 12 |
| 13 | Overall Dimensions | Head Length | in (mm) | 34.4 (874) | 34.4 (874) | 42.9 (1090) | 42.9 (1090) | 13 |
| | | Length with Forks | in (mm) | 82.4 (2093) | 82.4 (2093) | 90.8 (2306) | 138.8 (3527) | 14 |
| | Width | Chassis | in (mm) | 32.5 (826) | | 32.5 (826) | | 15 |
| | | Operator Platform | | - | | 35.6 (904) | | 16 |
| | Wheelbase | Forks Raised | in (mm) | 63.6 (1615) | | 63.6 (1615) | 83.5 (2121) | 17 |
| | Grade Clearance | Bottom of Pallet to Floor | % | 29.4 | | 29.4 | 22.4 | 18 |
| | Turning Radius | Minimum Outside | in (mm) | 71.5 (1817) | | 79.7 (2025) | 99.5 (2528) | 19 |
| | Right Angle Stacking ¹ | 40" x 48" Pallet | in (mm) | 81 (2057) | | 89 (2261) | 139 (3531) | 20 |
| | Truck Weight | With Standard Forks | lb (kg) | 1040 (472) | 1040 (472) | 1165 (528) | 1340 (608) | 21 |
| | 22 | Tires / Wheels | Drive Tire | in (mm) | 10 x 5 (254 x 127) Rubber | | 10 x 5 (254 x 127) Rubber | |
| Load Wheels | | | in (mm) | 3.25 x 6 (83 x 152) Poly | | 3.25 x 6 (83 x 152) Poly | | 23 |
| 24 | Speed - Travel | No Load | mph (kph) | 3.7 (5.9) | | 8.7 (14.0) | | 24 |
| | | Full Load | mph (kph) | 3.0 (4.8) | 2.6 (4.1) | 6.4 (10.3) | 5.9 (9.5) | 25 |
| 26 | Speed - Lift / Lower | Empty | seconds | 3.6 / 5.1 | | 3.6 / 5.1 | | 26 |
| | | Full Load | seconds | 5.1 / 4.8 | 6.1 / 4.7 | 5.1 / 4.8 | 6.1 / 4.7 | 27 |
| 28 | Max Battery Size | L x W x H | in (mm) | 31 x 13.25 x 31.62 (787 x 337 x 803) | | 31 x 13.25 x 31.62 (787 x 337 x 803) | | 28 |
| 29 | Amp Hr Capacity | Max (6-hr) | Ah | 750 | | 750 | | 29 |
| 30 | Weight | Min / Max | lb (kg) | 800 / 1500 (363 / 680) | | 900 / 1500 (408 / 680) | | 30 |
| 31 | Lead Length | Position "B" | in (mm) | 20 (508) | | 20 (508) | | 31 |
| 32 | Connector | | type | SB-175 Red | | SB-175 Red | | 32 |

¹ Add 6-8" for ease of operation. Includes 1" clearance on each side of load

Specifications

| RPB Walkie/Rider | | | Single Pallet | | | Double Pallet | | | |
|------------------|----------------|---|---------------|-------------|-------------|---------------|-------------|-------------|----|
| SPECIFICATIONS | 9 | Nominal Fork Length | in | 36 | 42 | 48 | 84 | 96 | 9 |
| | | Actual Fork Length | in (mm) | 35.7 (907) | 41.7 (1059) | 47.7 (1212) | 83.7 (2126) | 95.7 (2431) | |
| | 17 | Wheelbase (Forks Raised) | in (mm) | 51.6 (1311) | 57.6 (1463) | 63.6 (1615) | 83.5 (2121) | 83.5 (2121) | 17 |
| | 18 | Grade Clearance | % | 36.4 | 32.5 | 29.4 | 22.4 | 22.4 | 18 |
| | 19 | Turning Radius | in (mm) | 68.0 (1728) | 73.9 (1876) | 79.7 (2025) | 99.5 (2528) | 99.5 (2528) | 19 |
| | 20 | Right Angle Stacking Aisle ^{1,2} | | | | | | | 20 |
| | | 40" Load Width | in (mm) | 77 (1956) | 83 (2108) | 89 (2261) | 126 (3200) | 139 (3531) | |
| | | 42" Load Width | in (mm) | 77 (1956) | 83 (2108) | 89 (2261) | 126 (3200) | 139 (3531) | |
| | | 48" Load Width | in (mm) | 77 (1956) | 83 (2108) | 89 (2261) | 126 (3200) | 139 (3531) | |
| | | 90° Intersecting Aisle ¹ | | | | | | | |
| | | 40" Load Width | in (mm) | 63 (1600) | 66 (1676) | 68 (1727) | 80 (2032) | 82 (2083) | |
| | 42" Load Width | in (mm) | 64 (1626) | 67 (1702) | 70 (1778) | 81 (2057) | 83 (2108) | | |
| | 48" Load Width | in (mm) | 67 (1702) | 70 (1778) | 73 (1854) | 85 (2159) | 86 (2184) | | |
| 21 | Truck Weight | lb (kg) | 1110 (504) | 1138 (516) | 1165 (528) | 1303 (591) | 1340 (608) | 21 | |

¹ Add 6-8" for ease of operation

² Includes 1" clearance on each side of load

Technical Information

Standard Equipment

1. 24-volt electrical system.
2. Separately excited drive motor and controller system.
3. Environmental protection package for wet, cooler and freezer applications.
4. Spyglass display readout includes battery discharge indicator with lift lockout, (3) hour meters, scheduled maintenance reminders, and fault-code displays for on-board diagnostics.
5. Cruise control with anti-tape down feature. (walkie/rider only)
6. Electronic brake system.
7. Key switch.
8. Adjustable battery retainers.
9. SB-175 red battery connector.
10. Polyurethane load wheels with string-guard.
11. Rubber drive tire with string-guard.
12. Heavy-duty spring-loaded caster wheels with string-guard (walkie/rider only).

Optional Equipment

1. Magnetic mount convenience tray with stretch wrap holder.
2. Coast control. (walkie/rider only)
3. Sidetracker with coast control. (walkie/rider only)
4. Cushioned platform mat. (walkie/rider only)
5. Tilt-down load backrest with EZ release (48" or 60" extension).
6. Slip on/off load backrest (48" or 60" extension).
7. Battery compartment rollers.
8. Toggle switch in lieu of key switch.
9. Vulkolan load wheel option.
10. Nonmarking rubber, traction treaded rubber or flat poly drive tire options.
11. Special paint.

Operator Platform & Control Features

A spacious operator platform and compact hood design offers the operator a variety of comfortable

positions for reduced fatigue and sustained productivity. Optional cushioned platform mat provides added comfort.

A wide, 190° steering arc allows exceptional turning radius with minimal effort. Spring-loaded handle and roomy steering control head promote effortless movement into the operating range. Large thumb- or fingertip-actuated butterfly speed controls provide easy and precise operation. Ergonomic layout of lift, lower and horn buttons deliver comfortable operation. Large reversing switch on the end of the control head changes travel direction if operator contact is made.

Removable, soft grip, high-speed grab bar (walkie/rider only) provides the operator with a firm hold for maximum security and comfort. A center mounted control pod provides efficient operation of lift/lower, high speed and horn functions. Standard cruise control on walkie/rider trucks is activated by depressing the high-speed button on the grab bar. This allows the operator to maintain high-speed travel, without the need to hold down the button, thereby reducing fatigue and improving operating efficiency.

A two position lever located at the base of the truck's handle on the walkie/rider actuates an optional Coast Control feature, allowing the truck to coast for more efficient order picking. A switch conveniently located on either side of the control handle will activate the walkie/rider's optional Sidetracker feature. Used in conjunction with the Coast Control, this feature allows the operator to walk beside the truck while performing low-level order picking, for greater efficiency and productivity.

Electrical

Heavy-duty 24-volt electrical system incorporates a rugged 5.1 HP drive motor to handle a variety of

demanding applications. Curtis 1297 separately excited control system offers improved travel speeds for exceptional operator efficiency, with proportional plugging that provides smooth, precise stops and directional changes. All components are designed to withstand wet, cold and/or freezer applications to -20° F (-28.9° C). Elimination of contactors and enhanced thermal capabilities mean optimum performance and minimal downtime. On-board diagnostics and automatic replication of truck settings simplify fleet maintenance.

Battery

Maximum battery size –
31"L x 13.25"W x 31.62"H

375 Ah minimum / 750 Ah maximum

SB-175 red connector standard.
Optional connectors available.

Brake System

Electrical disc system utilizes regenerative motor torque prior to brake actuation for less component wear and longer life. System eliminates needed adjustments and hydraulic components for reduced maintenance. Brake actuation occurs when the handle is in the upper and lower braking range.

Fork Assembly

Forks are 9¼" wide and constructed from ¼" plate steel, designed with a reinforced tip for rugged durability. Lengths available in 30", 36", 42", 48", 54", 60" and 72" for standard single pallet fork options. Double pallet standard options include 72", 84" and 96" lengths. All with standard 27" wide fork spread.

Proven push-type lift linkage design uses rugged 1½" x 1½" solid steel tie rods that absorb high impact shocks caused by dockboards and dock-plates. Alloy steel fork slides facilitate pallet entry and exit eliminating the need for entry rollers or discs. Tie rods are positively aligned and pinned

to eliminate the need for field adjustments. Full-length, angle iron reinforcements enhance torsion strength for increased durability and longer life.

Wheels

6" wide poly load wheels with string guards offer increased floor surface contact and help prevent debris from getting into axles and bearings. Load wheels swing through a small 7" arc to achieve a full 6" lift.

Heavy-Duty Stability Caster Design

Heavy-duty, shim-free, polyurethane spring-loaded dual action casters mounted under the rider platform provide maximum stability in uneven floor conditions. Threaded fastener design means adjustments are made quickly and easily.

Hydraulics

Heavy-duty integrated lift pump and motor design features an overload valve to protect hydraulic components, and includes a hydraulic flow regulator and solenoid release valve.

Drive Unit Assembly

Quiet, spiral beveled gear drive system with sealed ball bearings, provides solid performance with low steer effort. Five-nut removal of the drive tire simplifies replacement when needed. Drive motor brush inspection is easily accessible. Separately excited drive motor with internal fan provides improved ventilation resulting in better performance and lower overall ownership costs.

Ease of Maintenance

One-piece cover with two-bolt removal makes access to the drive unit, and major components quick and easy. All lubrication fittings are easily accessible with the truck upright and the battery in place.

Notes:

Barrett Industrial Trucks meet or exceed all ASME/ANSI B56.1 Safety Standards for Powered Industrial Trucks and conform to the requirements of Underwriter's Laboratories as to fire and electrical shock hazard for "E" classifications. Performance data shown represents nominal values, which may be obtained under typical operating conditions of machine. Barrett Industrial Trucks reserves the right to make product changes relating to specifications, colors, or equipment without notice. For more information, contact your local Barrett Industrial Trucks representative.