

SGB Series

Walkie/Rider Tow Tractor

10,000 lb.
Rolling Load Capacity



Dimensions

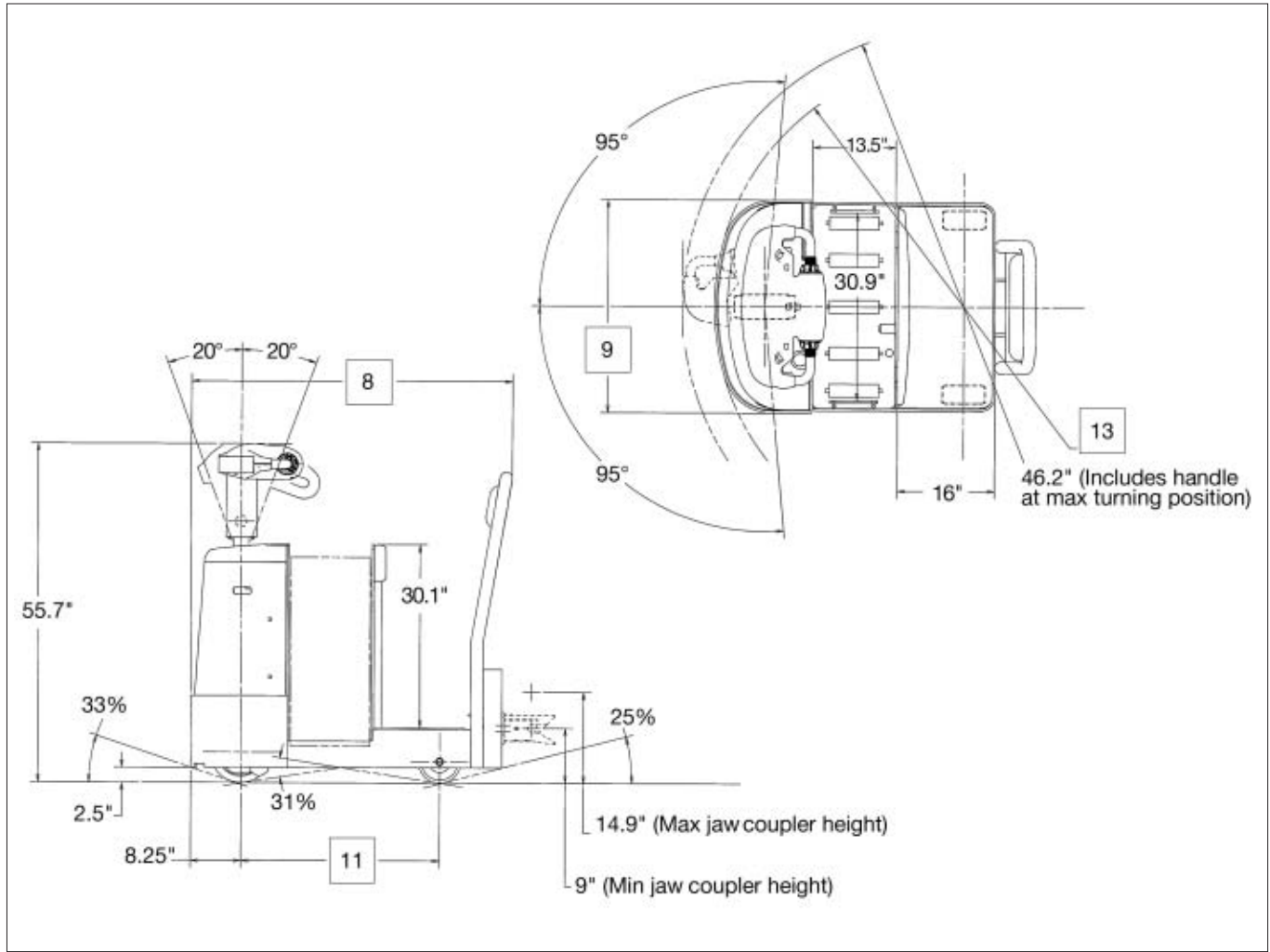

Adjustable Coupler Plates

Coupler plate allows each type of coupler to be adjustable in 1" increments

Type		Coupler Heights	
		Minimum	Maximum
Jaw Coupler	in (mm)	9.0 (228)	14.9 (380)
Tow Eye	in (mm)	9.3 (236)	15.3 (387)
Pin & Clevis	in (mm)	7.3 (186)	13.3 (337)

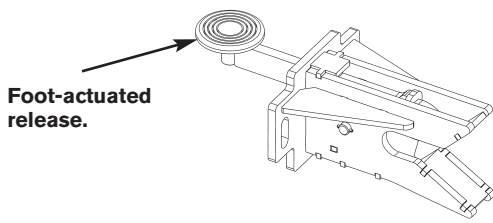

Jaw Coupler

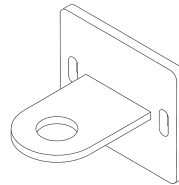

Tow Eye

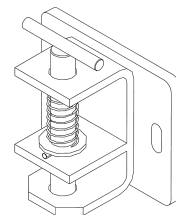

Pin & Clevis

10,000 lb. rolling capacity

Main Truck Specifications

CHARACTERISTICS	1	Manufacturer		Barrett	1	
	2	Model	Model designation	SGB	2	
			Long model code	SGTT1W4G20BV		
	3	Rolling Load Capacity		lb (kg)	10,000 (5000)	3
	4	Power Type	Electric		24 Volt	4
	5	Operator Type	Stand-up		Walkie/Rider	5
6	Tire Type			Solid Rubber	6	
DIMENSIONS	7	Wheels	Number - front/rear		1 / 2	7
	8	Overall Dimensions	Length - less coupler	in (mm)	52.8 (1340)	8
			Width - chassis	in (mm)	35.1 (890)	
			Height - top of steerhead	in (mm)	55.7 (1415)	
	9					9
	10					10
	11	Wheelbase		in (mm)	32.7 (830)	11
	12	Grade Clearance	Under chassis	%	31	12
	13	Turning Radius	Minimum outside	in (mm)	41 (1040)	13
	14	Front Overhang		in (mm)	8.25 (210)	14
PERFORMANCE	15	Truck Weight	Less battery	lb (kg)	1140 (541)	15
			Drive tire	in (mm)	4 x 10 (102 / 254)	
			Trail wheels	in (mm)	7 x 3 (180 x 75)	
18	Speed - Travel	Gear ratio 14.1:1				18
			No load	mph (kph)	8.7 (14)	
			Full load	mph (kph)	5 (8)	
19	Drawbar Pull	Normal	lb (kg)	200 (91)	19	
		Maximum	lb (kg)	710 (322)		
BATTERY	20	Battery Compartment	L x W x H	in (mm)	32 x 13.5 x 31 (813 x 343 x 803)	20
	21	Amp Hr Capacity	Min / Max (6-hr)	Ah	450 / 750	21
	22	Weight	Min / Max	lb (kg)	854 / 1500 (387 / 680)	22
	23	Lead Length	Position "B"	in (mm)	20 (508)	23
	24	Connector		type	SB 175 Red	24

*Compartment dimensions shown without battery gates. (31" x 13.5" x 31" with gates.)



Steerhead includes two butterfly controls allowing thumb or fingertip actuation of travel and direction.

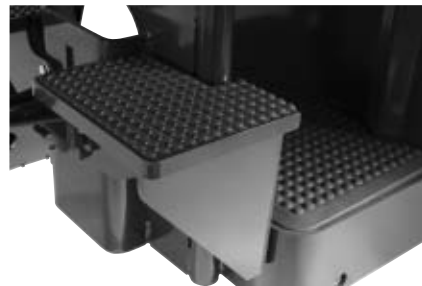

Rugged twin picking steps designed with traction padding are available as optional equipment.

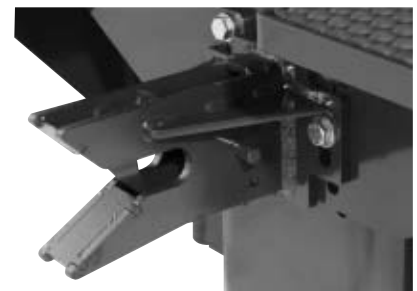

Standard jaw coupler has a robust design for secure towing. Its foot-operated release is conveniently located inside the operator compartment.



Optional convenience tray keeps operator items organized.



Optional battery rollers make change out quick and easy.

Technical Information

SGB series

Standard Equipment

1. 24-volt electrical system
2. Separately excited drive motor and control system
3. Programmable speed settings up to 8.7 mph
4. Coast control and integrated sidetracker
5. Adjustable steer head with low effort switches
6. Automatic jaw couple with foot-operated release
7. Environmental protection package for cooler and freezer applications (to -20°F/ -28.9°C)
8. Spyglass display readout includes battery discharge indicator with lift lockout, 3 hour meters and scheduled maintenance timer
9. On-board diagnostics
10. Electronic brake system; Push button parking brake
11. Key switch
12. Cushioned platform mat for greater operator comfort
13. Padded front wall and backrest
14. SB-2 (175 Amp Red) battery connector
15. 7" x 4" polyurethane trail wheels
16. 4" wide solid rubber drive tire

Optional Equipment

1. Battery compartment rollers and removable drop-in side gates
2. Fixed steer head
3. 60" load backrest
4. Convenience tray
5. Toggle switch in lieu of key switch
6. Twin picking steps
7. Non-marking, traction rubber and polyurethane drive tire options
8. Rubber and non-marking trail wheel options available
9. Towing eye, pin and clevis and other optional coupler designs available
10. Variety of paint options available

Operator Area and Control Features

T-style, adjustable steer head combined with cushioned platform and fully padded compartment provide an impressive workplace to achieve maximum operator comfort and reduced fatigue resulting in sustained productivity.

The steer head's wide, 190° steering arc allows for precise maneuvering in tight spaces with minimal effort. Its ergonomic layout of soft touch switches also includes two large, thumb-actuated butterfly speed controls for simple operation.

Its standard coast with integrated sidetracker and optional twin picking steps offer increased efficiency during low level order picking. A roomy, low profile compartment (8.8" platform height) permits easy entry/exit and walk-through.

The tow tractor comes standard with a heavy-duty automatic jaw coupler equipped with a foot-operated release located inside the operator compartment. Optional couplers are also available. (See page 3 for details.)

Electrical

Heavy-duty 24 volt electrical system incorporates a rugged 5.1 HP drive motor to handle a variety of demanding applications. Separately excited control system offers fast travel speeds for exceptional operator efficiency, with proportional plugging for smooth, controlled stops. All components are designed to withstand cold and/or freezer applications to -20° F (-28.9° C). Elimination of contactors and enhanced thermal capabilities mean optimum performance and minimal downtime. On-board diagnostics and automatic replication of truck settings simplify fleet maintenance.

Brake System

Electrical disc system incorporates regenerative motor torque prior to brake actuation for less component wear and longer life. System eliminates needed adjustments and hydraulic components for reduced maintenance.

Tires

Wide drive tire and trail wheels with standard string guards offer increased floor surface contact and eliminate debris from getting into axles and bearings.

Drive Unit Assembly

Vertically-mounted balanced drive system with drive motor, transmission and drive tire reduces steer effort and prevents unbalanced torque conditions. Five-bolt assembly simplifies drive tire replacement when needed. Drive motor brush inspection is easily accessible by removing 2 bolts. Internal fan provides additional ventilation of motor and components to keep system running cooler resulting in better performance and lower overall ownership costs.

Ease of Maintenance

One-piece cover makes access to the drive unit assembly quick and easy. Combined number and color-coded wiring system simplifies servicing. All lubrication fittings are easily accessible with the truck upright and battery in place. Maintenance reminders can be set using the handset tool.

Customized Operational Settings

Use of handset tool allows customized setting of basic operational functions, including: forward and reverse speeds, acceleration rate and plugging. Optional beeper for travel (reverse and/or forward) can be enabled. Battery discharge parameters can also be adjusted.

Barrett Industrial Trucks
240 N. Prospect Street
Marengo, IL 60152 USA
Phone (815) 568-0061
Fax (815) 568-0179
www.barrett-trucks.com

Barrett Industrial Trucks reserves the right to make product changes relating to colors, equipment or specifications without notice. For more information, contact your Barrett representative.

BARRETT
Industrial Trucks