

BARRETT
Industrial Trucks

WS Series

Walkie Straddle Stacker

3,000 & 4,000 lb.
Capacities



Mast Specifications & Rated Capacities

Dimensions

WS-30/WS-40

Mast Type	Maximum Fork Height	Overall Height Lowered	Free Lift	Capacity at 24" Load Center	
				WSN-30	WSN-40
TWO STAGE LO FREE LIFT	105.5 (2680)	72 (1829)	5.5 (140)	3000 (1360)	4000 (1814)
	115.5 (2934)	77 (1956)	5.5 (140)	3000 (1360)	4000 (1814)
	127.5 (3239)	83 (2108)	5.5 (140)	3000 (1360)	4000 (1814)
	139.5 (3543)	89 (2261)	5.5 (140)	3000 (1360)	4000 (1814)
	151.5 (3848)	95 (2413)	5.5 (140)	3000 (1360)	3950 (1792)
TWO STAGE HI FREE LIFT	105.5 (2680)	72 (1829)	51 (1295)	3000 (1360)	4000 (1814)
	115.5 (2934)	77 (1956)	56 (1422)	3000 (1360)	4000 (1814)
	127.5 (3239)	83 (2108)	62 (1575)	3000 (1360)	4000 (1814)
	139.5 (3543)	89 (2261)	68 (1727)	3000 (1360)	4000 (1814)
	151.5 (3848)	95 (2413)	74 (1880)	3000 (1360)	3950 (1792)
THREE STAGE	155.5 (3950)	72 (1829)	51 (1295)	3000 (1360)	4000 (1814)
	170 (4318)	77 (1956)	56 (1422)	3000 (1360)	3750 (1701)
	188 (4775)	83 (2108)	62 (1575)	3000 (1360)	3450 (1565)
	202 (5131)	89 (2261)	68 (1727)	2850 (1293)	3275 (1486)
	216 (5486)	95 (2413)	74 (1880)	2700 (1225)	2950 (1338)

Outrigger dimensions may affect truck capacity.

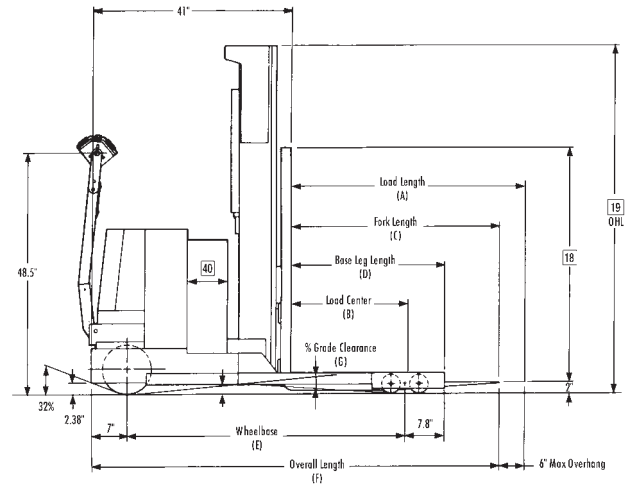
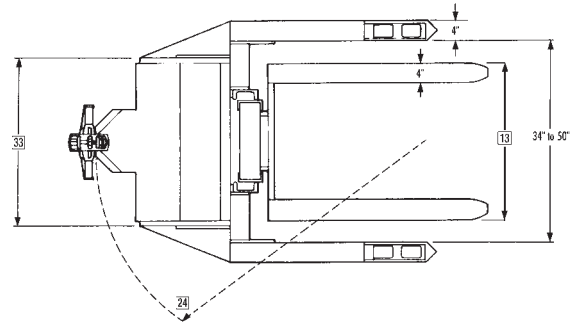

Right Angle Stacking Aisle

WS-30/WS-40

Load Length	Load Width					
	30"	32"	36"	40"	42"	48"
30"	58 (1473)	59 (1499)	60 (1524)	60 (1524)	61 (1549)	62 (1575)
32"	59 (1499)	60 (1524)	60 (1524)	61 (1549)	61 (1549)	63 (1600)
36"	63 (1600)	63 (1600)	64 (1626)	65 (1651)	65 (1651)	67 (1702)
40"	73 (1854)	72 (1829)	68 (1727)	67 (1702)	67 (1702)	69 (1753)
42"	76 (1930)	75 (1905)	74 (1880)	70 (1778)	70 (1778)	69 (1753)
48"	80 (2032)	79 (2007)	75 (1905)	74 (1880)	74 (1880)	76 (1930)

- 5" spacing between loads/pallets.
- Add 1" for WS-40 models using Triplex mast.
- Add 5.25" for 24v models.
- Add 6"-10" for ease of operation.

Note: Consult factory for trucks with larger pallet spacing or side shifter.

Aisle requirements determined by method of storing and spacing.

Dimensional Data*

WS-30/WS-40

	(A)-Load Length					
	30"	32"	36"	40"	42"	48"
(B) - Load Center	15 (381)	16 (406)	18 (457)	20 (508)	21 (533)	24 (610)
(C) - Fork Length	24 (610)	30 (762)	30 (762)	36 (914)	36 (914)	42 (1067)
(D) - Base Leg Length	20 (508)	21 (533)	25 (635)	27 (686)	28 (711)	35 (889)
(E) - Wheelbase**	46 (1168)	47 (1194)	51 (1295)	53 (1346)	54 (1372)	61 (1549)
(F) - Overall length**	65.2 (1656)	71.2 (1808)	71.2 (1808)	77.2 (1961)	77.2 (1961)	83.2 (2113)
(G) - Grade Clearance %	16 (406)	15.5 (394)	15 (381)	14.5 (368)	14 (356)	13.5 (343)

*Specified load length will determine fork and base leg lengths.

**Add 5.25" for 24v models (13.5" long battery compartment).

3,000 - 4,000 lb. capacity

Main Truck Specifications

CHARACTERISTICS				Barrett		Barrett			
1	Manufacturer's Name			Barrett		Barrett		1	
2	Model	Model designation		WS-30		WS-40		2	
3	Load Capacity	Rated capacity	lb (kg)	3000 (1500)		4000 (2000)		3	
4	Load Center	Distance	in (mm)	24 (600)		24 (600)		4	
5	Power Type	Electric	volt	12	24	12	24	5	
6	Operator Type			Walkie Straddle		Walkie Straddle		6	
7	Tire Type	Front and rear		Rubber / Poly		Rubber / Poly		7	
8	Wheels	Number (x=driven) - front/rear		4 / 1x		4 / 1x		8	
DIMENSIONS	9	Mast	Max. fork height (MFH)	in (mm)	105.5 (2680)		105.5 (2680)		9
	10		Freelift (FL)	in (mm)	51 (1295)		51 (1295)		10
	11	Forks	Thickness x width	in (mm)	1.6 x 4.2 (40 x 106)		1.6 x 4.2 (40 x 106)		11
	12		Length	in (mm)	42.1 (1070)		42.1 (1070)		12
	13		Min. fork spread (o.d.)	in (mm)	8 (203)		8 (203)		13
	14		Max. fork spread (o.d.)	in (mm)	30 (762)		30 (762)		14
	15		Fork lowered height	in (mm)	2.0 (51)		2.0 (51)		15
	16	Overall Dimensions	Length - with forks	in (mm)	83 (2108)	88.3 (2242)	83 (2108)	88.3 (2242)	16
	17		Length - less forks	in (mm)	78.6 (1996)	83.9 (2131)	78.6 (1996)	83.9 (2131)	17
	18		Height - top of standard LBR	in (mm)	48 (1219)		48 (1219)		18
	19		Mast lowered (OHL)	in (mm)	72 (1829)		72 (1829)		19
	20		Mast extended with LBR	in (mm)	153.5 (3899)		153.5 (3899)		20
	21		Width - minimum outrigger i.d.	in (mm)	34 (864)		34 (864)		21
	22		Width - maximum outrigger i.d.	in (mm)	50 (1270)		50 (1270)		22
	23		Outrigger Height	in (mm)	4 (102)		4 (102)		23
	24	Turning Radius	Minimum outside	in (mm)	68.4 (1737)	73.6 (1870)	68.4 (1737)	73.6 (1870)	24
25	Min. Right Angle Stack	48" L x 40" W pallet (add clearance)	in (mm)	74 (1880)	79.3 (2014)	74 (1880)	79.3 (2014)	25	
26	Truck Weight	103.5" Mast, empty, no battery	lb (kg)	2200 (1000)		2400 (1090)		26	
PERFORMANCE	27	Speeds	Travel - full load	mph (kph)	2.4 (3.9)	2.6 (4.2)	2.4 (3.9)	2.3 (3.7)	27
	28		Travel - no load	mph (kph)	3.1 (5.0)	3.2 (5.2)	3.1 (5.0)	3.1 (5.0)	28
	29		Lift - full	fpm (mm/sec)	17 (86)	20 (102)	14 (71)	17 (86)	29
	30		Lift - empty	fpm (mm/sec)	28 (142)	38 (193)	28 (142)	38 (193)	30
	31		Lower - full	fpm (mm/sec)	50 (254)	50 (254)	55 (279)	55 (279)	31
	32		Lower - empty	fpm (mm/sec)	30 (152)	30 (152)	30 (152)	30 (152)	32
CHASSIS & WHEELS	33	Overall Width	Width	in (mm)	34.5 (876)		34.5 (876)		33
	34	Wheelbase	Distance between axles on centers	in (mm)	61 (1550)	66.3 (1684)	61 (1550)	66.3 (1684)	34
	35	Tire Size	Drive tire	in (mm)	10 x 5 (254 x 127)		10 x 5 (254 x 127)		35
	36		Load wheels - tandem	in (mm)	4 x 2.75 (102 x 70)		4 x 2.75 (102 x 70)		36
	37	Service Brake	Type		Drum and Shoe		Drum and Shoe		37
BATTERY	38	Type		Lead Acid		Lead Acid		38	
	39	Compartment Size	Width x Height	in (mm)	34.5 x 31 (876 x 788)		34.5 x 31 (876 x 788)		39
	40		Length	in (mm)	8.25 (210)	13.5 (343)	8.25 (210)	13.5 (343)	40
	41	Amp Hr Capacity	Min / Max (6-hr)	Ah	375 / 750		375 / 750		41
	42	Weight	Minimum	lb (kg)	410 (187)	960 (436)	410 (187)	960 (436)	42
	43		Maximum	lb (kg)	725 (330)	1500 (681)	725 (330)	1500 (681)	43
	44	Lead Length	Position "B"	in (mm)	20 (508)		20 (508)		44
45	Connector	type		SB-175 Grey		SB-175 Grey		45	

NOTE: 12-Volt models are standard.

24-Volt model specifications based on larger 34.5" x 13.5" x 31"H battery compartment size.

Technical Information WS Series

Standard Equipment

- 12-volt electrical system
- Premium heavy-duty motor
- Curtis PMC 1205 transistor travel controller
- Reversing switch in handle
- Electronic horn
- Curtis 701 solid state LCD hour meter
- Key switch
- Oil filter in hydraulic system
- 31" wide carriage
- 48" h x 32.6" w load backrest
- Fixed base legs – 34" to 50" (order in 1" increments)
- Duplex FFL mast: 72" OHL / 105.5" MFH / 51" FL
- Wire screen mast guard
- Fork lengths: 30", 36", 42"
- Fork spacing: 10" min. to 30" max. o.d.
- Rubber drive tire – 10" x 5"
- Tandem poly load wheels – 4" x 2.75"

Optional Equipment

- 24-volt electrical system with 8.25" or 13.5" wide battery compartment
- Fuel gauge type battery discharge indicator
- Battery discharge indicator with lift interrupt
- Battery compartment rollers with drop-in gates
- Choice of Duplex (high or low FL) or Triplex masts
- Adjustable base legs for greater load handling flexibility
- Pallet centering device assures uniform load stacking and reduced product and pallet damage
- Cold storage protection
- Side shifter with single function hydraulics and IHR
- Manual lift and lower levers for full feathering
- Non-marking rubber or polyurethane drive tires

Steer Control Features

Steering handle with outside stationary grips provides low-effort pull-down into the operating range. Thumb-operated butterfly speed controls inside the control head provide easy and precise truck control. Large safety reversing switch, on the control handle, reverses truck travel direction if operator contact is made. Control head features lift, lower, and horn buttons within convenient operator reach. Gas charged cylinder returns the handle with uniform force, while a rubber stop at the end of travel prevents switch shock.

Electrical

12-volt electrical system with heavy-duty series wound class 'H' insulated drive motor. PMC transistor travel controller for smooth, controlled acceleration, infinitely variable speed control, and increased energy efficiency. Key switch and solid state LCD hour meter are standard. Steer handle wiring harness constructed of extra flexible stranded tinned copper conductor wiring with silicone insulation for increased durability and reduced maintenance.

Drive Unit Assembly

Exclusive balanced drive system designed with drive motor, transmission and drive tire mounted in a vertical column. This stationary design greatly reduces steer effort, unbalanced torque conditions, and cable flexing, for enhanced reliability and reduced maintenance costs.

Brake System

Dual braking positions within upper and lower handle movement range enhance operating efficiency. The 7" diameter brake drum provides excellent braking response, with the largest braking surface in its class.

Hydraulic System

Hydraulic system features heavy-duty lift pump and motor, overload protection valve, solenoid release valve for lowering, check valve, and flow regulator. Return line filtering protects the system against environmental contaminants.

Steering

190° steering arc (95° each side of center) allows for precise maneuvering in tight spaces for increased operator efficiency. Steer handle is mounted to the bottom of drive unit for maximum leverage and steering ease.

Frame Assembly

Rugged frame with 4" x 4" solid steel base legs for maximum strength and durability. Base legs with tandem load wheels reduce friction and enhance wheel bearing life. Tapered base leg tips reduce the risk of pallet hang-up and assist in pallet positioning. Steel covers for rugged durability and component protection. Powder coat paint for a durable, high gloss, scratch resistant finish.

Battery

- Battery compartment: 34.5" x 8.25" x 31"
- Adjustable battery retainers
- Minimum battery weight: 410 lbs.
- SB-2 battery connector (175 Amp – grey)

Ease of Service

Removing five bolts allows quick and simple drive tire replacement. The hub has a built-in drive wheel puller to simplify the job. One screw removal, simplifies drive motor brush inspection. Lubrication fittings are easily accessible with the truck upright and the battery in place. Removal of four hood bolts allows quick access to internal components. Number coded electrical wiring simplifies wiring harness maintenance. One nut removal of the brake drum allows easy access for periodic inspection and maintenance.

Barrett Industrial Trucks
240 N. Prospect Street
Marengo, IL 60152 USA
Phone (815) 568-0061
Fax (815) 568-0179
www.barrett-trucks.com

Barrett Industrial Trucks reserves the right to make product changes relating to colors, equipment or specifications without notice. For more information, contact your Barrett representative.

BARRETT
Industrial Trucks